

OPERATOR'S MANUAL

W401 ATTACHING KIT FOR 8-1/2 FOOT BACKHOE 3-POINT HITCH LINKAGE & HYDRAULIC HOOK-UP TO TRACTOR HYDRAULIC SYSTEMS

General Description

The W401 Mounting and Hydraulics Kit will attach the 8-1/2' Backhoe to the 3-point hitch of certain tractor models which appear on our factory-approved list.

This kit includes two hoses which can be used in connecting the backhoe control valve to the tractor hydraulic system. Additional hydraulic components or kits will be required to complete the hook-up to the tractor hydraulic system. Refer to "Hydraulic Hook-Up" section below for further information. The W360 and W452 PTO Pump and Reservoir Kits are also available as options.

The backhoe is mounted on the tractor lower link arms and an adjustable upper link is supplied to replace the tractor upper link. A set of stabilizer arms are included. They bolt from the adjustable upper link to the backhoe mainframe, locking the hoe rigidly in one position.

IMPORTANT - Tractor lower links must be kept free of lifting forces at all times, after installation of the W401 Kit, by keeping tractor quadrant lever in lowered position.

Hydraulic Hook-Up

If the W360 or W452 PTO Pump and Reservoir Kit is to be used, refer to the manual supplied with that kit for instructions on proper assembly.

There are four basic methods of hooking up the 8-1/2' Backhoe to the hydraulic system of a tractor. The correct method for the particular tractor will depend on the remote couplers available, whether a loader valve or other accessory valve is connected to the tractor system, and whether the tractor has an open-center system (constant pumping of oil to control

valve and back to reservoir) or a closed-center system (no flow of oil until there is a demand at one hydraulic cylinder). The four hook-up methods are described below.

IMPORTANT - Follow instructions carefully when connecting backhoe to tractor hydraulic system.

The following decal is located on the left side of the backhoe valve shroud:

IMPORTANT

IMPROPER HYDRAULIC HOOK-UP CAN CAUSE SERIOUS DAMAGE TO VALVE

- REFER TO ATTACHING KIT OR PTO PUMP KIT MANUAL FOR PROPER HYDRAULIC HOOK-UP.
- NEVER PRESSURIZE RETURN PORT OF VALVE OR RESTRICT RETURN HOSE.
- ALWAYS MOVE TRACTOR 3-POINT HITCH CONTROL TO FULLY LOWERED POSITION WHILE BACKHOE IS MOUNTED TO TRACTOR.

NOTE - Do not connect hoses from the backhoe control valve to the tractor hydraulic system until initial assembly of mounting kit is complete.

1. OPEN-CENTER SYSTEM WITH RETURN OIL NOT REQUIRED FOR LUBRICATION - Fig 1:

The pressure hose (13) on the backhoe control valve should be connected to the pressure port of the tractors remote couplers or directly to the tractor valve. Install hose sleeve supplied with backhoe on pressure hose to cover fitting on backhoe valve and secure with plastic tie provided. The return hose (13) on the backhoe control valve should be connected directly to a port on the reservoir, as shown in Fig 1.

IMPORTANT - Never connect the return hose to a tractor remote coupler which can be pressurized. Accidental pressurization can cause serious damage to backhoe valve.

2. OPEN-CENTER SYSTEM WITH RETURN OIL REQUIRED FOR LUBRICATION - Fig 2:

On some tractors, the return oil can not be routed directly to the reservoir because it is required for the lubrication of other functions. Check this characteristic with your dealer. The pressure hose (13) on the backhoe control valve should be connected to the pressure port of the tractors remote couplers or directly to the tractor valve. Install hose sleeve supplied with backhoe on pressure hose to cover fitting on backhoe valve and secure with plastic tie provided. The return hose (13) on the backhoe control valve must be connected to a surge relief valve as shown in Fig 2.

NOTE - The surge relief valve (part number 10293) is not supplied with the backhoe or mounting kit and must be ordered separately to complete this type of hydraulic hook-up.

Complete the hydraulic hook-up by connecting the surge relief valve to the return port of tractor remote couplers or directly to the tractor valve, and by connecting a hose from the TANK port of the surge relief valve to the tractor reservoir as shown in Fig 2. The surge relief valve is used to protect the backhoe valve from damage caused by accidental pressurization or high back pressure build-up. If this happens, oil will be vented from the TANK port of the surge relief valve to the tractor reservoir to prevent loss of vented oil.

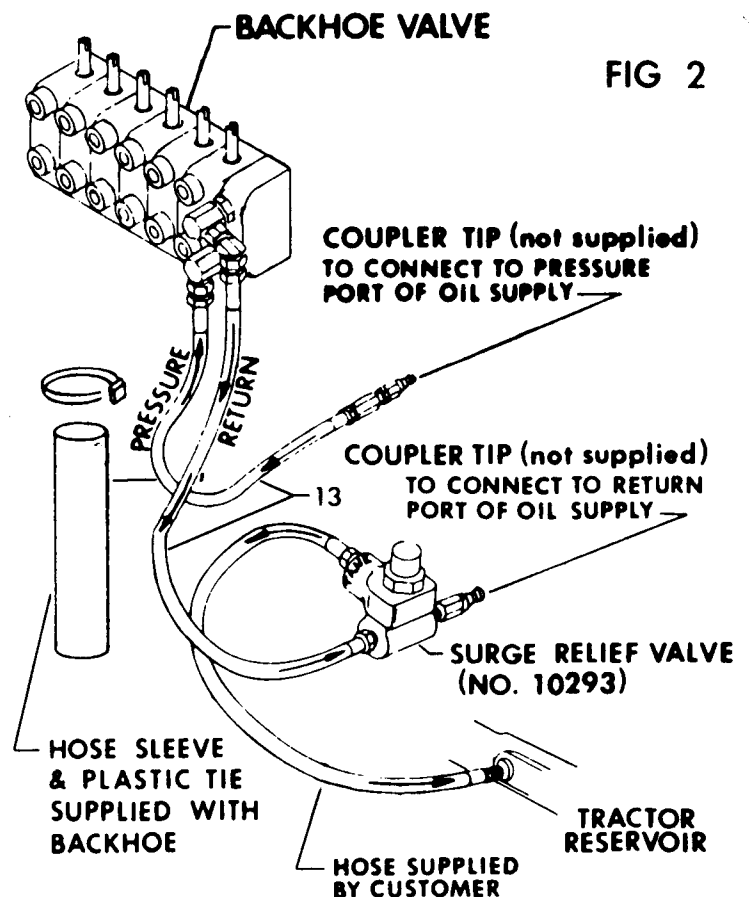
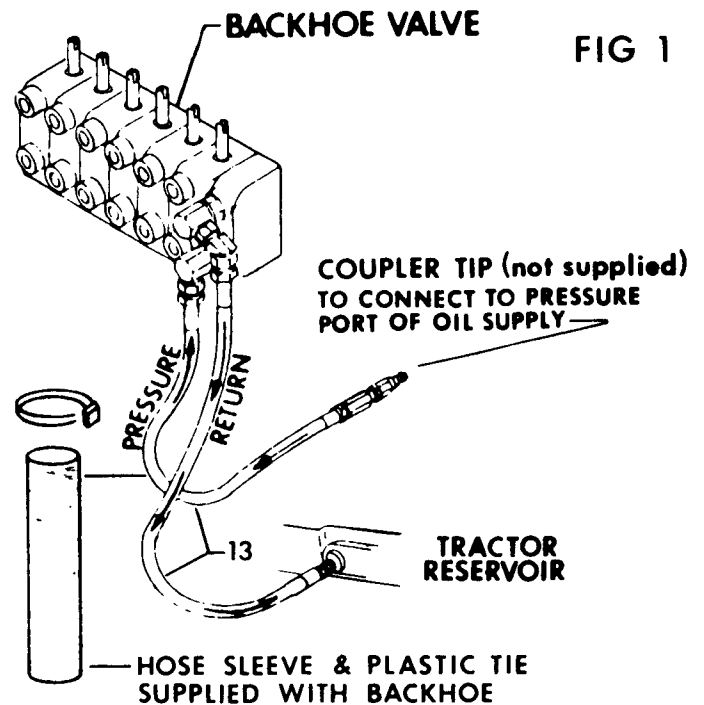

3. OPEN-CENTER SYSTEM WITH LOADER VALVE OR OTHER ACCESSORY VALVE CONNECTED TO THE TRACTOR HYDRAULIC SYSTEM:

When a loader valve or other accessory valve must be connected to the tractor hydraulic system in addition to the backhoe control valve, a W364 Power Beyond Kit is required. This kit converts the backhoe valve so that pressurized hydraulic oil can be directed to another open-center valve for a loader or other accessory. This allows the backhoe valve and the other valve to be connected to the tractor hydraulic system simultaneously, without the inconvenience of using a flow diverting valve.

Since the W364 Power Beyond Kit is used with open-center tractor hydraulic systems, oil constantly flows from the pump, through the backhoe valve and the loader valve or other accessory valve, and then to the reservoir. Refer to the Owner's Manual supplied with the W364 Kit for instructions on proper assembly.

4. CLOSED-CENTER SYSTEM:

Because a closed-center system requires no flow of oil through the backhoe control valve when the levers are in a neutral position, the backhoe must be converted for this operation by installing a W403

Closed-Center Hydraulic Kit. As long as the engine and pump are running, a constant stand-by oil pressure of approximately 2000 PSI or more will be maintained in the system. Pressurized oil is available instantaneously to go to work when any one of the operating valves is opened.

The hook-up of the backhoe to the closed-center system requires more than connecting it to the remote couplers. Some of the required devices are:

- A. A flow restrictor in the pressure line to keep the speed of the backhoe operation within safe and acceptable limits.
- B. A main relief valve pressure setting in the backhoe control valve that is always higher than the tractor system.
- C. A closed-center plug to make it a non-circulating or a demand type system.
- D. A low pressure surge relief valve in the return line to keep the tractor back pressure surges from damaging the backhoe control valve seals or tractor system.

The W403 Closed-Center Hydraulics Kit is required to convert the backhoe valve so that it may be connected to a closed-center tractor hydraulic system. Refer to the Owner's Manual supplied with the W403 Kit for instructions on proper assembly.

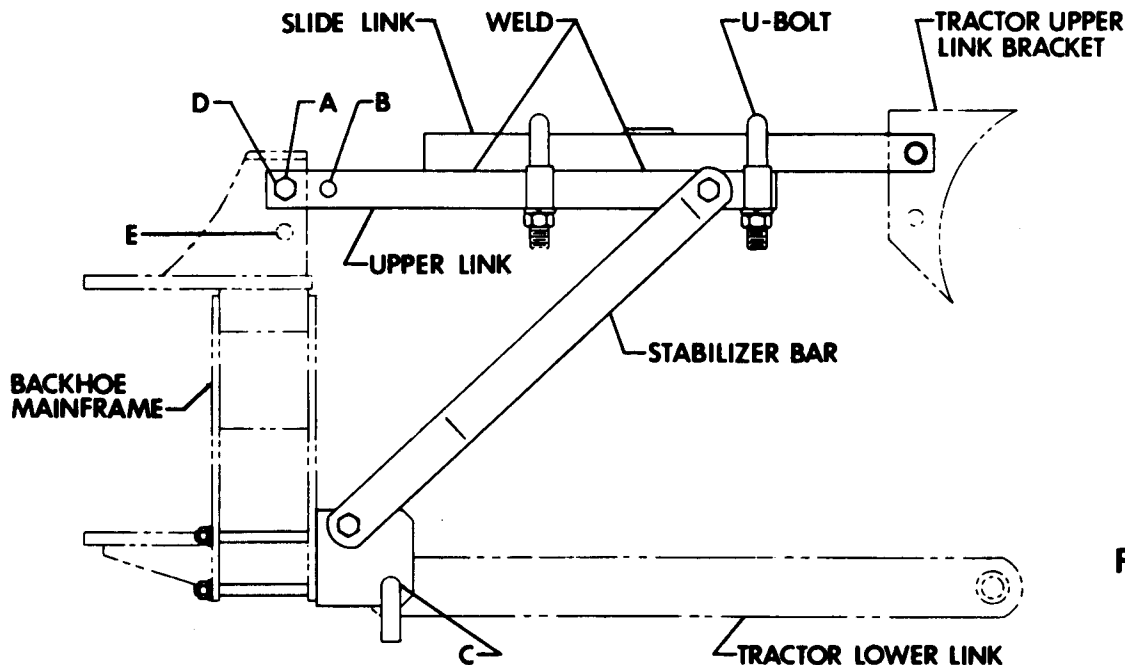

FIG 3

Assembly

1. Attach lower link mounts (22, 23) to backhoe mainframe using eight bolts, lock-nuts, and flat washers (1, 4, 9) as shown in Fig 3 and 4. Torque to 50 ft-lb.

IMPORTANT - Tighten all hardware to the torque requirements specified in the Torque Chart, Page 6, of this manual, unless otherwise specified.

2. Attach long leg of stabilizer bars (24) to outside of lower link mounts (22, 23) using two bolts, nuts, lockwashers, and spacers (3, 5, 7, 20) as shown in Fig 4. Do not tighten hardware at this time.

⚠ WARNING TO PREVENT BODILY INJURY DO NOT OPERATE BACKHOE UNLESS STABILIZER BARS (24) ARE PROPERLY INSTALLED AND ADJUSTED. FAILURE TO DO SO MAY RESULT IN BACKHOE BEING THRUST UPWARD, CRUSHING OPERATOR AGAINST TRACTOR CAB OR R.O.P.S.

3. Use hoist to raise the backhoe mainframe so that the boom pivot pin is approximately 16" off the ground.

4. Back tractor close to the backhoe. Connect tractor lower link arms to lower link mounts at position C, Fig 3, using two L-pins (15), two cotter pins (11), and two wire form cotter pins (12), as shown in Fig 4.

NOTE - If tractor has a Category II hitch, install two bushings (16) in lower link arms, as shown in Fig 4.

5. There are several variations in the method the W401 linkage may be installed. This allows the kit to be used with a variety of approved tractor models. These variations, see Fig 3, are listed as follows:

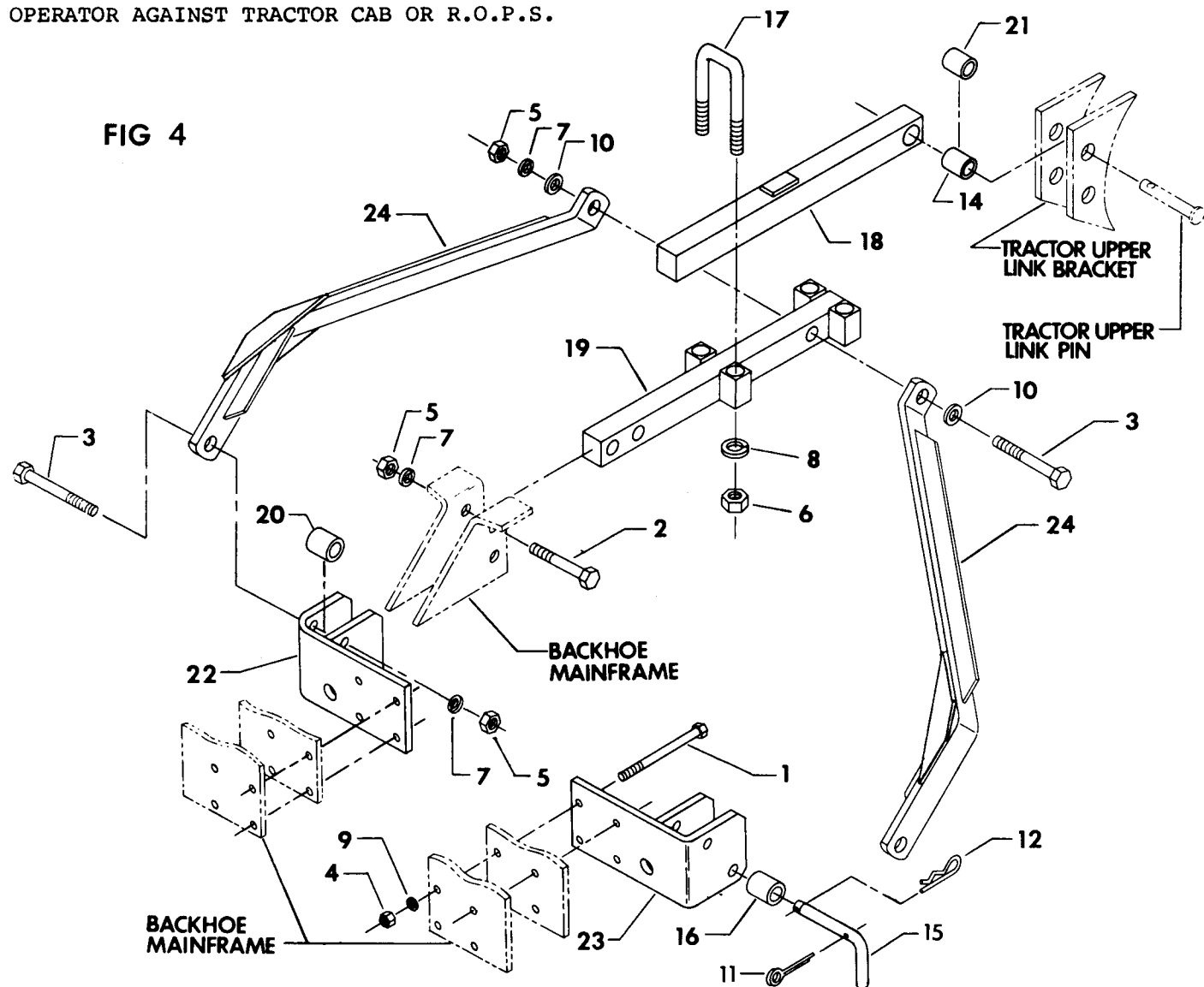

Assembly - continued

Choice 1 - Mainframe may be attached to either hole (A), or hole (B) in the upper link.

Choice 2 - Upper link may be attached to either hole (D), or hole (E) in the mainframe.

Choice 3 - Length of upper link mount assembly may be adjusted by extending or retracting slide link.

Choice 4 - Upper link may be attached with slide link on top, as shown in Fig 5, or with slide link on the bottom, as shown in Fig 6.

6. Position upper link assembly with slide link on top, as shown in Fig 3, and rest backhoe end between ears on mainframe. Loosely connect upper end of stabilizer bars (24) to upper link (19) using bolt, nut, lockwasher, and two flat washers (3, 5, 7, 10), as shown in Fig 3 and 4.

7. Using choices 1 thru 3 find the correct combination of holes so that the free end of upper link can be very nearly attached to tractor upper link bracket - with the backhoe mainframe in its present position (boom pivot pin approximately 16" off the ground). After determining the correct combination of holes, attach upper link to mainframe using bolt, nut, and lockwasher (2, 5, 7), as shown in Fig 4.

NOTE - If necessary, the stabilizer bars (24) may be detached from the upper link and the upper link may be turned over so that the slide link is on the bottom, as shown in Fig 6. Re-attach stabilizer bars to upper link.

8. Install bushing (14) or bushing (21) in the hole of slide link (18) that most closely matches the diameter of the tractor upper link pin, as shown in Fig 4. No bushing is necessary for Category II tractors.

9. Use hoist to raise or lower backhoe slightly until the hole in the slide link lines up with the tractor upper link bracket. Secure slide link in position using tractor pin. Tighten all hardware on stabilizer bars, and upper link bracket of mainframe at this time. Tighten U-bolt nuts evenly and torque to 260 ft. lb.

Tackweld slide link to upper link 2 places on each side, as shown in Fig 5 and 6.

⚠ CAUTION - *If links are not tack welded together, the weight of the backhoe will cause the upper link assembly to extend, allowing the mainframe to slip toward the ground.*

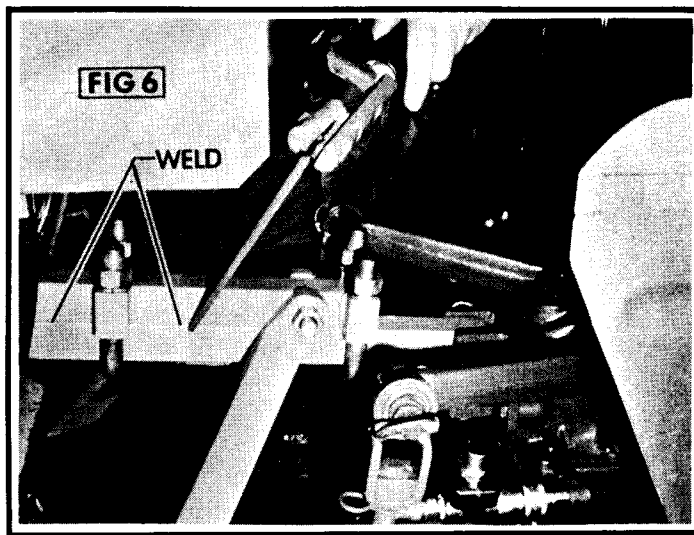
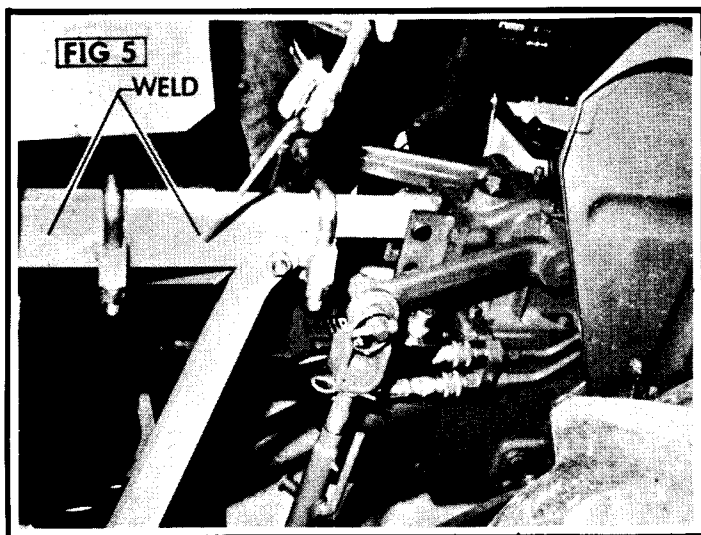

10. Check your installation very carefully to be sure all members are correctly installed and securely fastened.

11. Connect hoses from the backhoe control valve to the tractor hydraulic system as described in "Hydraulic Hook-Up" section.



Parts List

Index	Description	Part No.	Index	Description	Part No.
1	Bolt, 1/2 NF x 7-1/2 SAE Gr. 5 ..	7092	14	Bushing-Upper Link Cat I	750253
2	Bolt, 3/4 NF x 4" SAE Gr. 5	7257	15	L-Pin.....	775003
3	Bolt, 3/4 NF x 5" SAE Gr. 5	7264	16	Bushing-Lower Link Cat II ...	852198
4	Locknut, 1/2 NF.....	7515	17	U-Bolt.....	852262
5	Nut, 3/4 NF.....	7569	18	Slide Link Weldment.....	854500
6	Nut, 7/8 NF.....	7599	19	Upper Link Weldment.....	854505
7	Lockwasher, 3/4.....	8121	20	Spacer.....	854526
8	Lockwasher, 7/8.....	8126	21	Bushing - Upper Link John Deere.....	854528
9	Flat Washer, 1/2 SAE.....	8173	22	RH Lower Link Mount Weld.....	857200
10	Flat Washer, 3/4 SAE.....	8192	23	LH Lower Link Mount Weld.....	857205
11	Cotter Pin, 3/16 x 1-1/4.....	8582	24	Stabilizer Bar Weld.....	857210
12	Wire Form Cotter, #10.....	8624			
13	Hyd. Hose, 1/2 NPT x 54"	10988			

TORQUE VALUES			
Common bolts and nuts.		Tightening Torque \pm 20%	
SIZE	GRADE 2 	GRADE 5 	GRADE 8 
1/4-20 NC	70 in lb	115 in lb	165 in lb
1/4-28 NF	85 in lb	140 in lb	200 in lb
5/16-18 NC	150 in lb	250 in lb	350 in lb
5/16-24 NF	165 in lb	270 in lb	30 ft lb
3/8-16 NC	260 in lb	35 ft lb	50 ft lb
3/8-24 NF	300 in lb	40 ft lb	60 ft lb
7/16-14 NC	35 ft lb	55 ft lb	80 ft lb
7/16-20 NF	45 ft lb	75 ft lb	105 ft lb
1/2-13 NC	50 ft lb	80 ft lb	115 ft lb
1/2-20 NF	70 ft lb	105 ft lb	165 ft lb
9/16-12 NC	75 ft lb	125 ft lb	175 ft lb
9/16-18 NF	100 ft lb	165 ft lb	230 ft lb
5/8-11 NC	110 ft lb	180 ft lb	260 ft lb
5/8-18 NF	140 ft lb	230 ft lb	330 ft lb
3/4-10 NC	150 ft lb	245 ft lb	350 ft lb
3/4-16 NF	200 ft lb	325 ft lb	470 ft lb

NOTE - See tractor instruction manual or your tractor dealer for tightening of metric bolts.